

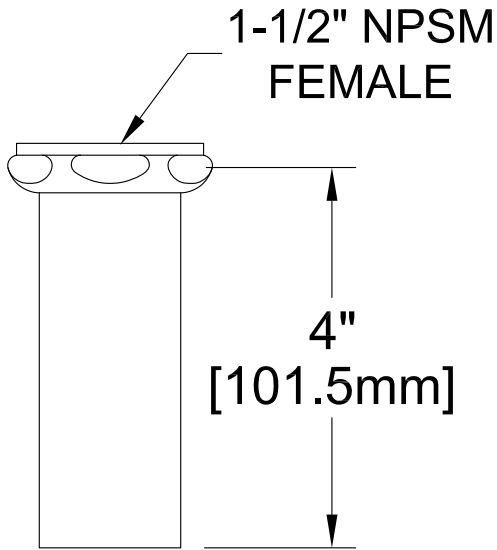

Customer/Wholesaler:	Date:	Job Name:	Model Specified:	Quantity:
Contractor:	Architect/Engineer:			

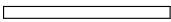

 6280-5000
1" WASHER

 73532
1-1/2" NUT

MODEL:

6544-0000 TAILPIECE 1 1/2 X 4 CR

OPTIONS OR MODIFICATIONS:

OTHER _____

FEATURES:

- * 1-1/2" NPSM FEMALE INLET
- * 4" LENGTH
- * CHROME PLATED

SYSTEM LIMITS

- * NONE

SHIPPING WEIGHT

- * 4.5 LBS

PRODUCT COMPLIANCE:

- * NONE