

APPLICATION:

PRODUCT NAME:  
**BASE DECK RIG**

JOB NAME:

MODEL:

QUANTITY:

ITEM NO.:

2903

OPTIONS OR MODIFICATIONS:  
 OTHER \_\_\_\_\_

FEATURES:

SHIPPING WEIGHT  
\* 75 LBS

PRODUCT COMPLIANCE:  
\* ASME A112.18.1 / CSA B125.1  
\* NSF 61 - Section 9  
\* NSF 372 (Low Lead Content)

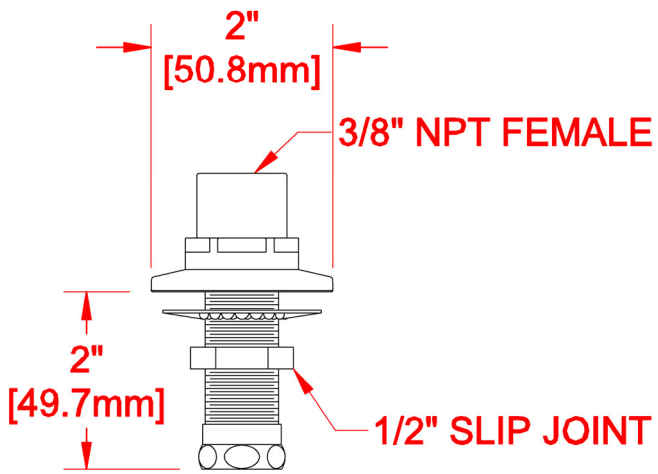

**ROUGH-IN:**

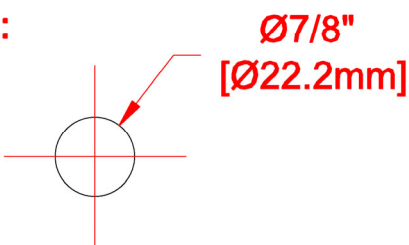

FISHER MANUFACTURING COMPANY  
TOLL FREE: 800-421-6162 - FAX: 800-832-8238  
information@fisher-mfg.com - www.fisher-mfg.com