

APPLICATION:
 JOB NAME:
 QUANTITY: ITEM NO.:

PRODUCT NAME:
DrainKing WASTE VALVE

MODEL:
 22306 DRAINING W/FLAT STRAINER & 19" X 21" OVERFLOW BRASS
 22322 DRAINING W/FLAT STRAINER & 14" X 16" OVERFLOW BRASS
 28940 DRAINING W/FLAT STRAINER & 19" X 21" OVERFLOW CHROME
 28967 DRAINING W/FLAT STRAINER & 14" X 16" OVERFLOW CHROME

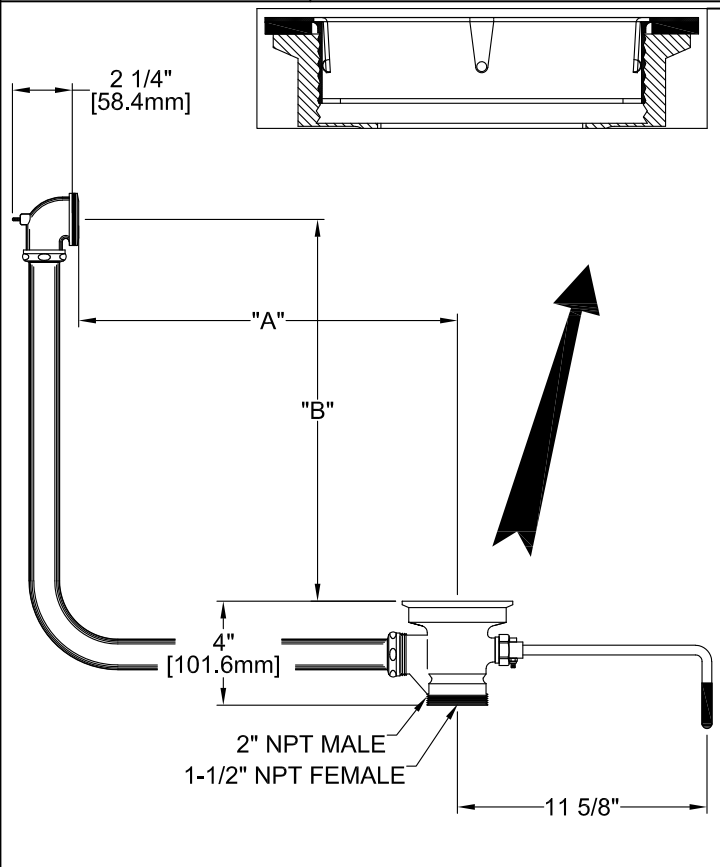

OPTIONS OR MODIFICATIONS:
 OTHER _____

- FEATURES:
- * DUAL TEFLON SEALS
 - * STAINLESS STEEL BALL
 - * CAST RED BRASS BODY
 - * EXTRA SURDY STAINLESS STEEL CLAMPING RING
 - * "CLEAR THROUGH" OPENING, NO NEED TO DISASSEMBLE IF SNAKING IS REQUIRED
 - * INDUSTRY STANDARD "SEALING" ANGLE - FITS FLUSH TO STANDARD STAINLESS STEEL SINKS
 - * STAINLESS STEEL FLAT STRAINER
 - * 1/4 TURN FULLY OPENS AND CLOSES VALVE

DRAIN RATE:
 * 12 GPM

SHIPPING WEIGHT
 * 10.0 LBS

PRODUCT COMPLIANCE:
 * ASME A112.18.2 / CSA B125.2

MODEL	19" X 21"	
	DIM "A"	DIM "B"
22306	19"	19-1/4"
28940	[482.6mm]	[489.0mm]

MODEL	14" X 16"	
	DIM "A"	DIM "B"
22322	14"	14-1/4"
28967	[355.6mm]	[362.0mm]

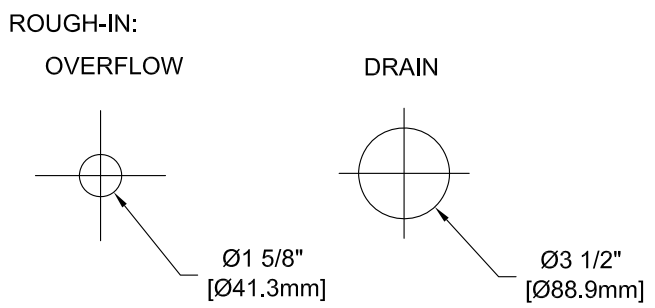

FISHER MANUFACTURING COMPANY
 TOLL FREE: 800-421-6162 - FAX: 800-832-8238
 information@fisher-mfg.com - www.fisher-mfg.com